

WATER / FOAM MONITOR ASSEMBLY FJM80 WTO

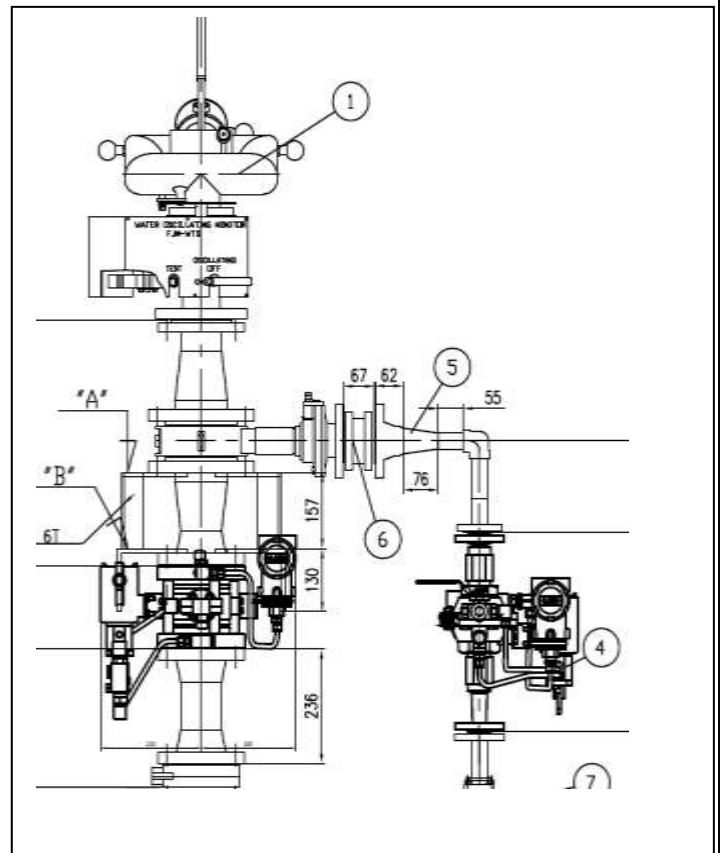
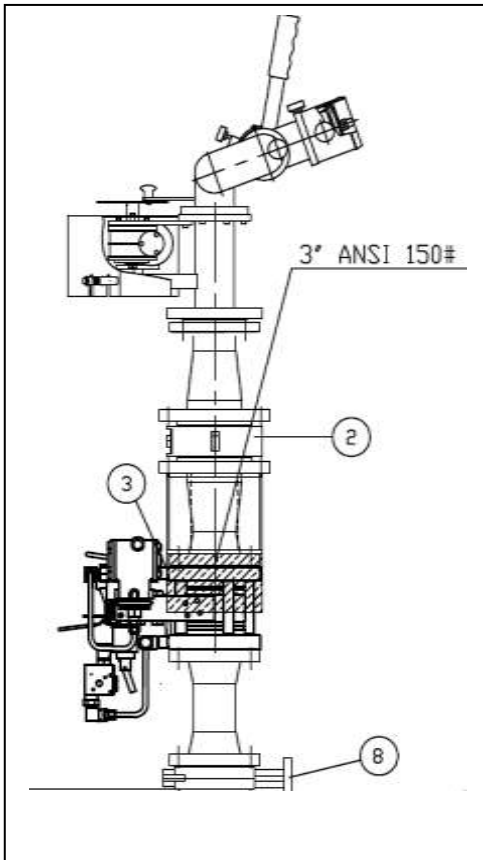

- | | | | |
|----------------------------|--------------------------------|---------------|------------|
| 1- Fog/jet fire monitor | 120m ³ /h at 7 bars | SS316 | ref 910969 |
| 2- Foam proportionner | 4 " | Bronze | |
| 3- Deluge valve water line | 3 " | Ni-AL-Br..... | ref 911369 |
| 4- Deluge valve foam line | 1 " | SS316 | ref 911371 |
| 5- Foam line pipe | | SS316 | |
| 6- Check valve | 2 " | SS316 | |
| 7- Ball valve | 1 " | SS316 | |
| 8- Butterfly valve | 3 " ANSI 150 #,Lug | Al-Br | |